

Fashion Bed Group

A Division of Leggett & Platt Incorporated

Parts List For Tuxedo Daybed

PART #361401 HARDWARE BAG FOR DAYBED

- (1) 1/4-20 1 1/4" COUNTER SUNK ALLEN HEAD SCREW-6
- (2) 1/4-20 1" FLAT ALLEN HEAD SCREW-8
- (3) 1/2" ID LOCK WASHERS-8
- (4) 3/8" OD METAL WASHER-8
- (5) ALLEN WRENCH-1

DAYBED PARTS:

- (6) LEFT SIDE-1
- (7) RIGHT SIDE-1
- (8) BACK PANEL-1

LINK SPRING PARTS:

- (9) LEFT BRACKET-2
- (10) RIGHT BRACKET-2
- (11) 5/16-18 SCREW-4
- (12) 5/16-18 HEX NUT-4
- (13) SUPPORT DECK-1

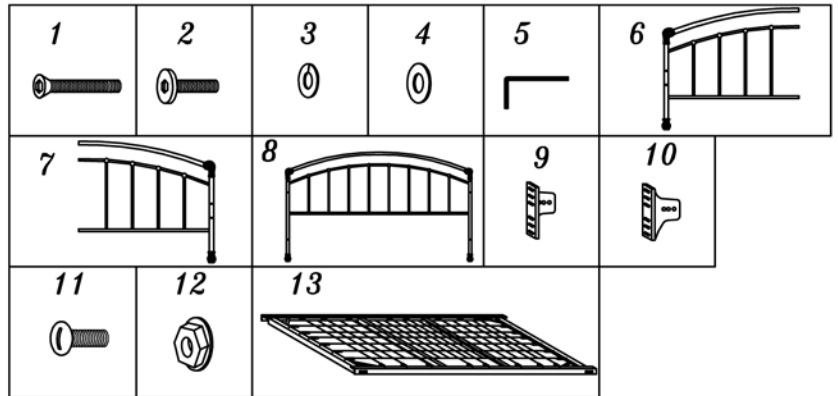

SAVE ALL PACKAGING MATERIALS UNTIL PRODUCT IS FULLY ASSEMBLED. HARDWARE AND SMALL PIECES MAY NOT BE SEEN AND BE ACCIDENTALLY DISCARDED WITH PACKAGING MATERIALS.

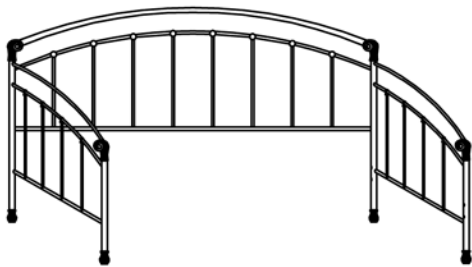

MATTRESS LINK SPRING FULLY ASSEMBLED

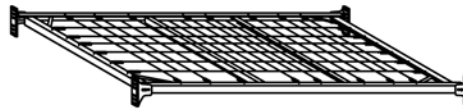

OPTIONAL

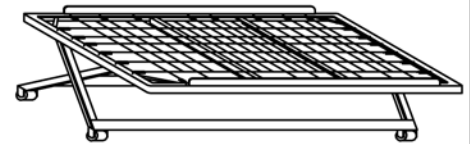

POP-UP TRUNDLE

DAYBED FULLY ASSEMBLED

Instruction Sheet

NOTE: •For ease of assembly you will need a helper.
•Periodically retighten all screws.

Step 1- Locate Hardware bags for Daybed & Link Spring Assembly

- Hardware bag for assembly Daybed is located inside the daybed carton box.
- Link spring hardware bag is located below the link spring cross bar.

Step 2- Link Spring Assembly

- Attach left & right brackets (9 & 10) to side rails using screws (11) and nuts (12).
See Figure 1

FIGURE 1

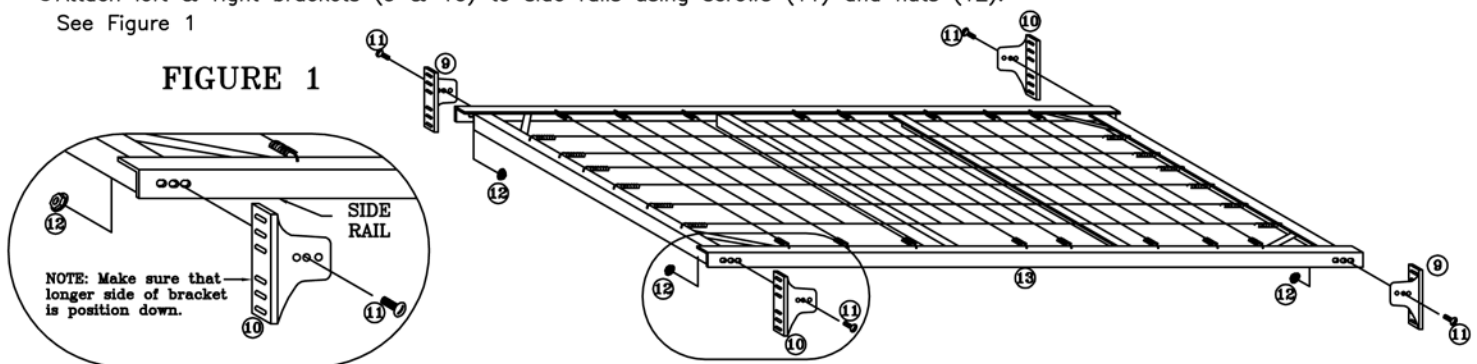

NOTE: Make sure that longer side of bracket is position down.

Instruction Sheet

Step 3- Attachment of Back panel to Daybed sides

- You must remove the metal bracket on the ends of the arms before attaching to the daybed back.
- Align holes in back panel (8) with end rails of left side (6). See Figure 2
- Secure back panel and left side with screws (1).
- Tighten screws with Allen wrench (5).
- Repeat on other daybed posts.

Must remove metal bracket

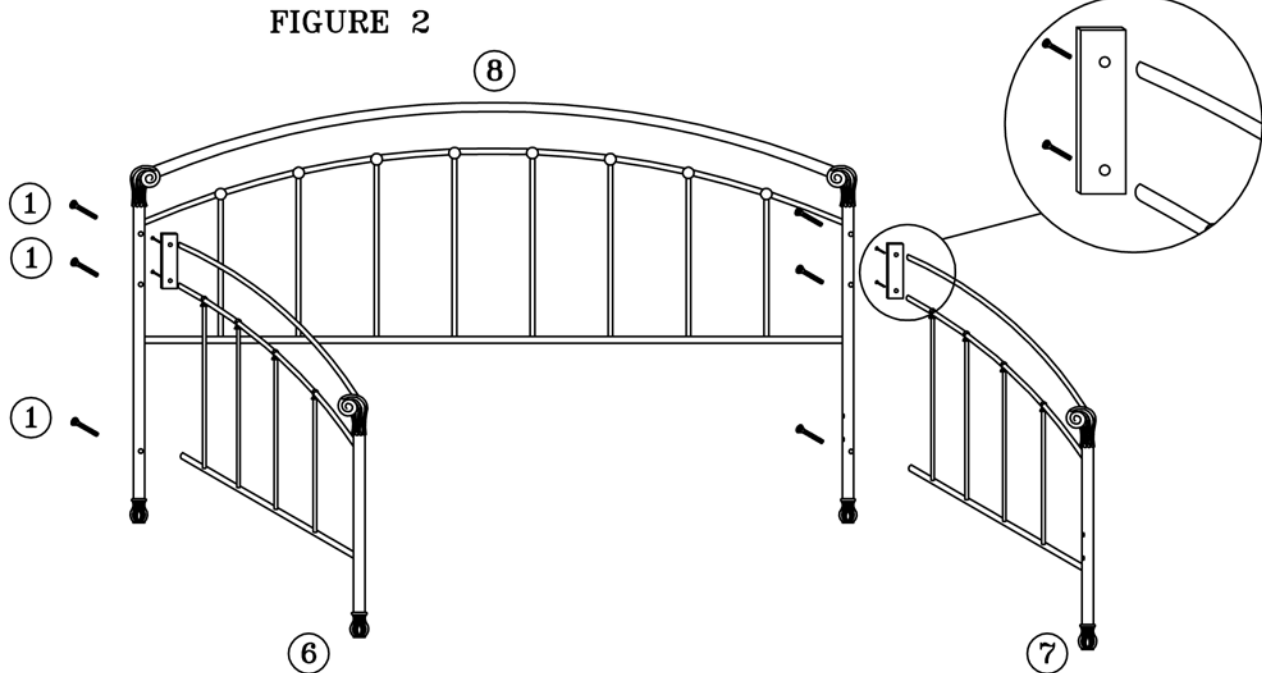

Step 4- Attachment of Link Spring to Daybed sides

- Bolt one metal bracket of the link spring to one daybed side post.
- For each post use 2 screws (2), 2 lock washers (3) and 2 washers (4). Loosely tighten. See Figure 3
- Repeat on other daybed posts.
- Tighten screws with Allen wrench (5).

FIGURE 3

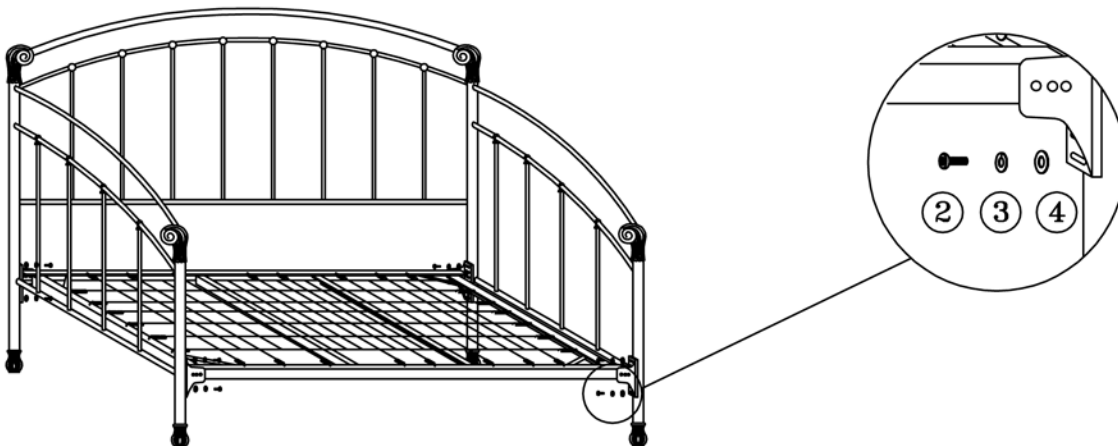

Instruction Sheet

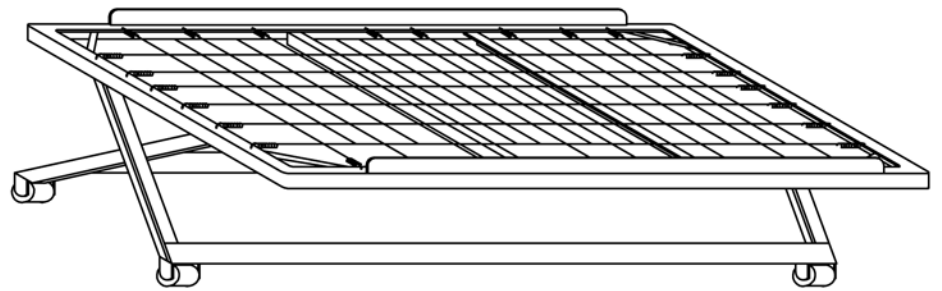
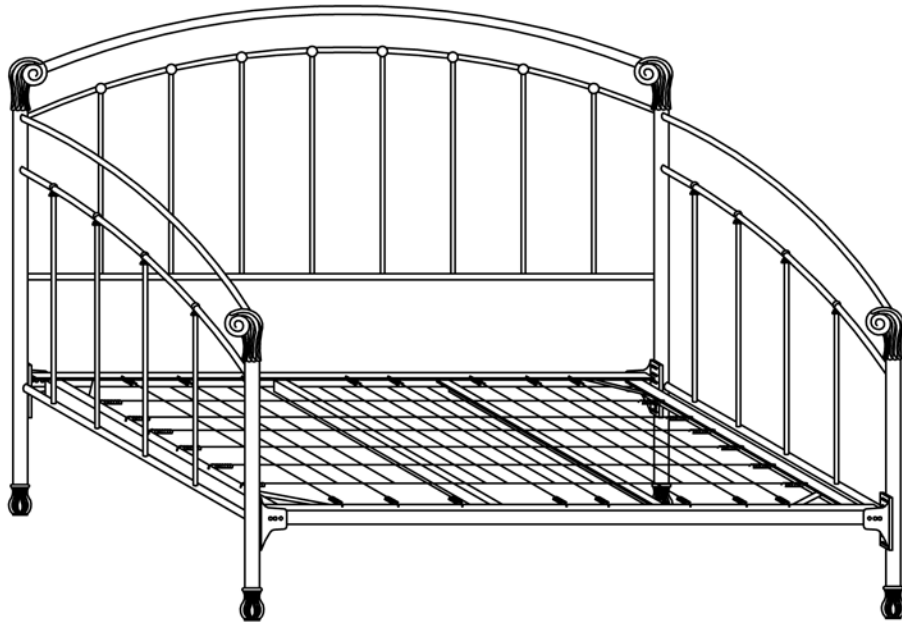

OPTIONAL

FIGURE 4